

Image shown may not reflect actual engine

## CATERPILLAR ENGINE SPECIFICATIONS

---

### V12, 4-Stroke-Cycle Diesel

Bore.....	137.2 mm (5.4 in)
Stroke.....	152.4 mm (6.0 in)
Displacement.....	27.03 L (1,649.47 in <sup>3</sup> )
Aspiration.....	Turbocharged / Aftercooled
Compression Ratio.....	15.6:1
Rotation (from flywheel end).....	Counterclockwise
Capacity for Liquids	
Cooling System.....	67.0 L (17.7 gal)
Lube Oil System (refill).....	139.0 L (36.7 gal)
Engine Weight, Net Dry (approximate)..	2,141 kg (4,720 lb)

---

## FEATURES

### Emissions

Non-Certified Rating.  
Meets Tier 1, Stage I emission requirements. Tier 1 refers to EPA (U.S.) standards. Stage I refers to European standards.

### Single Source Supplier

Caterpillar  
- Casts engine blocks, heads, cylinder liners, and flywheel housings  
- Machines critical components  
- Assembles complete engine  
- Factory-designed systems built at Caterpillar ISO 9001:2000 certified facilities  
Ownership of these manufacturing processes enables Caterpillar to produce high quality, dependable product.

### Testing

Prototype testing on every model:  
- proves computer design  
- verifies system torsional stability  
- functionality tests every model

Every Caterpillar engine is dynamometer tested under full load to ensure proper engine performance.

### Full Range of Attachments

Wide range of bolt-on system expansion attachments, factory designed and tested.

### Unmatched Product Support Offered Through Worldwide Caterpillar Dealer Network

More than 1,800 dealer outlets  
Caterpillar factory-trained dealer technicians service every aspect of your industrial engine  
99.7% of parts orders filled within 24 hours worldwide  
Caterpillar parts and labor warranty  
Preventive maintenance agreements available for repair before failure options

Scheduled Oil Sampling program matches your oil sample against Caterpillar set standards to determine:  
- internal engine component condition  
- presence of unwanted fluids  
- presence of combustion by-products

### Web Site

For all your industrial power requirements, visit [www.cat-industrial.com](http://www.cat-industrial.com).

**STANDARD ENGINE EQUIPMENT**

---

**Air Inlet System**

Aftercooler core, corrosion resistant coated, Air cleaner, regular duty, dry, service indicators, panel type air cleaners, Dual turbochargers, Jacket water aftercooled

Aftercooler core, corrosion resistant coated, Air cleaner, regular duty, dry, service indicators, cylindrical air cleaners, Turbocharged, Jacket water aftercooled

**Control System**

Governor, full range electronically controlled, Hydraulic electronic unit injection (HEUI) system, Air fuel ratio control, electronic, Electronic control module (ECM)

**Cooling System**

Thermostats and housing, Jacket water pump, gear driven, centrifugal, RH

**Exhaust System**

Exhaust manifold, dry, Exhaust elbow, dry 203 mm (8 in)

**Flywheels and Flywheel Housings**

Flywheel  
Flywheel Housing, SAE Standard Rotations

**Fuel System**

Fuel filter, RH with service indicators  
Fuel transfer pump  
Fuel priming pump

**Instrumentation**

Instrument panel, RH  
Engine oil pressure gauge  
Fuel pressure gauge  
Jacket water temperature gauge  
Engine oil temperature

**Lube System**

Crankcase breather, top mounted  
Oil cooler, RH  
Oil filler in valve cover and dipstick, RH  
Oil filter, RH  
Rear sump oil pan

**Mounting System**

Supports

**General**

Paint, Caterpillar yellow  
Vibration damper  
Lifting eyes

**PERFORMANCE CURVES**

**IND - A (Continuous) - DM2531-01**

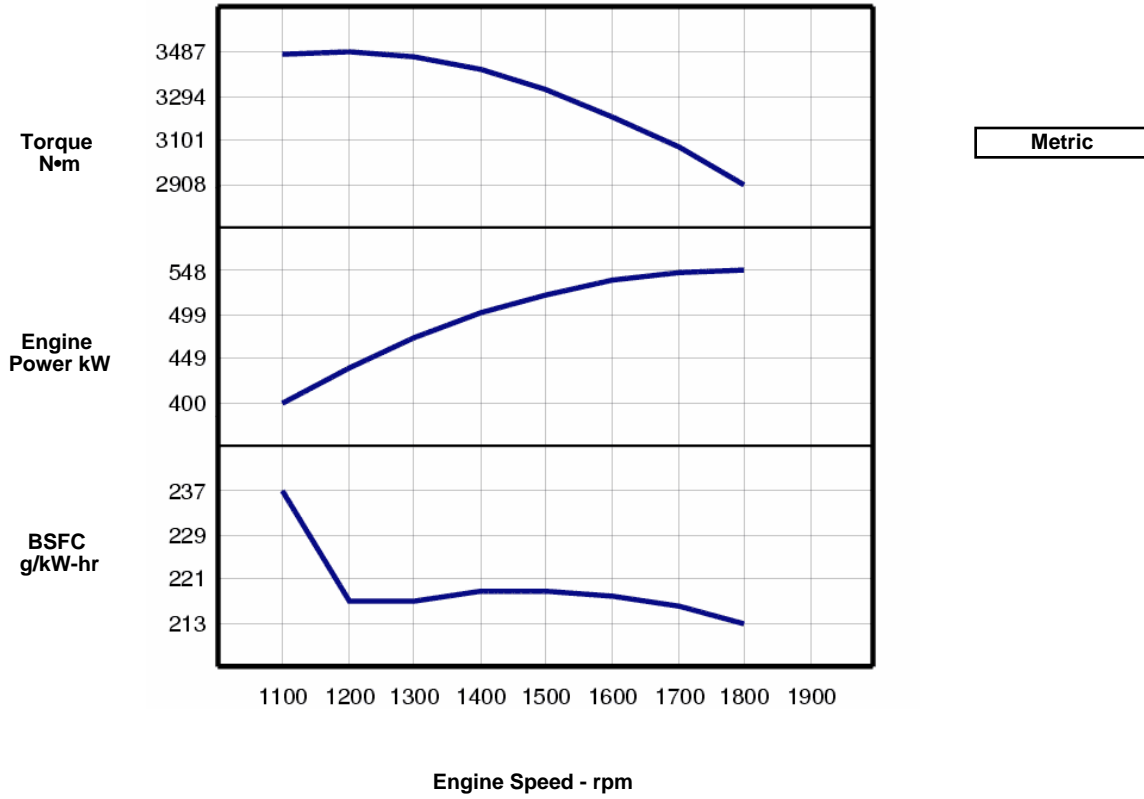

Engine Speed rpm	Engine Power kW	Torque N•m	BSFC g/kW-hr	Fuel Rate L/hr
1800	548	2908	212.9	139.1
1700	546	3066	216.1	140.6
1600	537	3205	217.8	139.4
1500	521	3319	218.7	135.9
1400	499	3405	219	130.3
1300	471	3460	217.2	122.0
1200	438	3487	216.5	113.1
1100	400	3476	236.5	112.9

**RATINGS AND CONDITIONS**

**IND - A (Continuous)** Continuous heavy duty service where the engine is operated at maximum power and speed up to 100% of the time without interruption or load cycling. Time at full load can be up to 100% of the duty cycle. Typical service examples are: pumping, ventilation, customer specs.

**Engine Performance** Engine performance is corrected to inlet air standard conditions of 99 KPA (29.31 IN HG) dry barometer and 25 deg C (77 deg F) temperature. These values correspond to the standard atmospheric pressure and temperature as shown in SAE J1995.

Performance measured using a standard fuel with fuel gravity of 35 degrees API having a lower heating value of 42,780 KJ/KG (18,390 BTU/LB) when used at 29 DEG (84.2 DEG F) where the density is 838.9 G/L (7.001 LB/US GAL).

The corrected performance values shown for Caterpillar engines will approximate the values obtained when the observed performance data is corrected to SAE J1995, ISO 3046-2 and 8665 and 2288 and 9249 and 1585, EEC 80/1269 and DIN 70020 standard reference conditions.

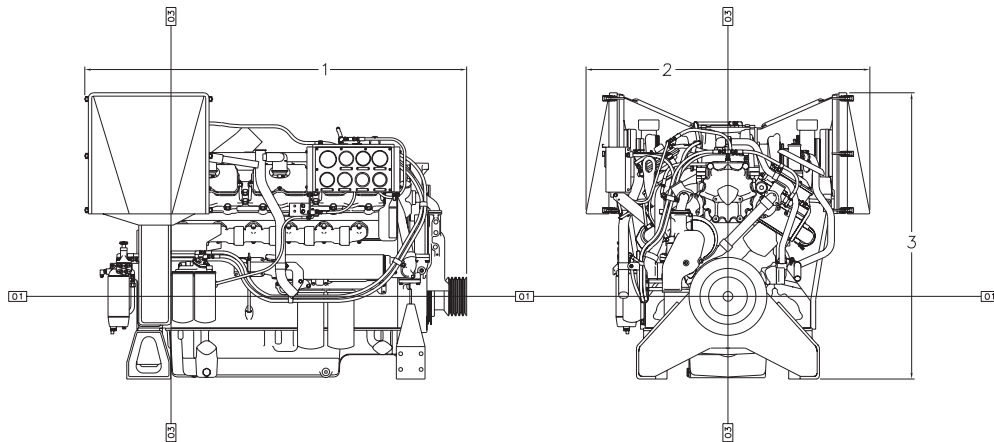

Engine Dimensions	
(1) Length	1995.4 mm
(2) Width	1483.4 mm
(3) Height	1496.1 mm

Note: Do not use for installation design. See general dimension drawings for detail (Drawing # 1362115 ).

Performance Number: DM2531-01

Feature Code: 412DI04

Materials and specifications are subject to change without notice.

© 2005 Caterpillar

All rights reserved.

The International System of Units (SI) is used in this publication.